

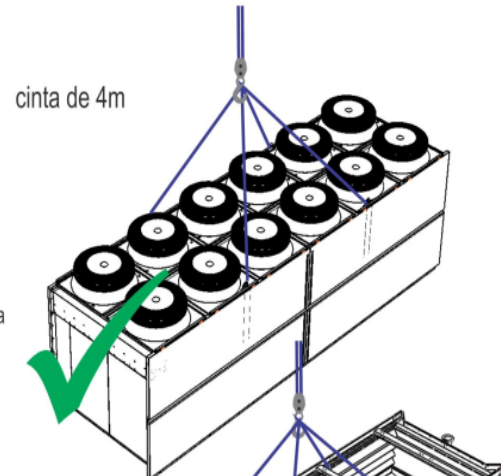

1- Erguendo ou suspendendo o condensador

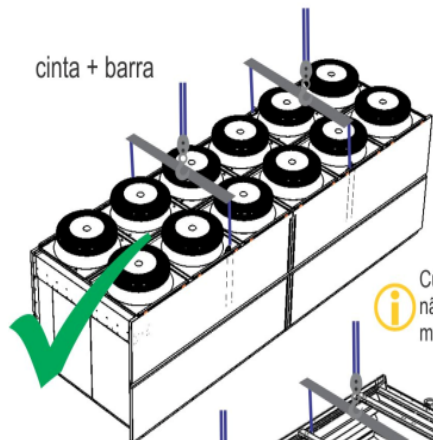
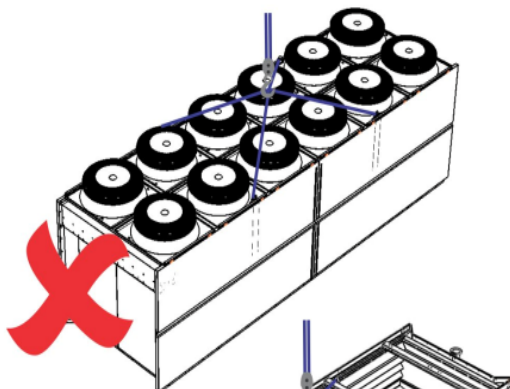

cinta + barra

cinta de 4m

 Cuidar para a cinta não danificar a máquina.

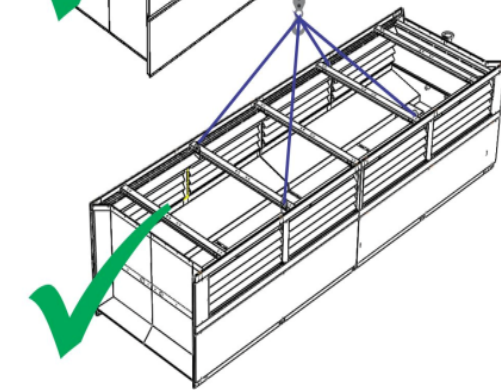
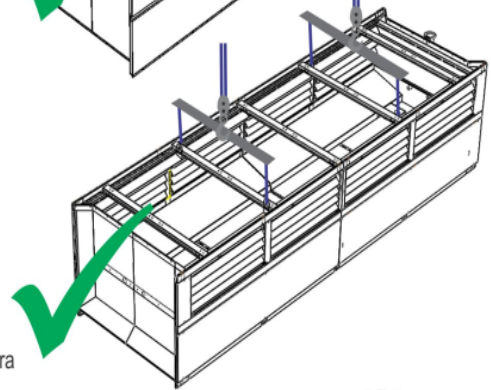
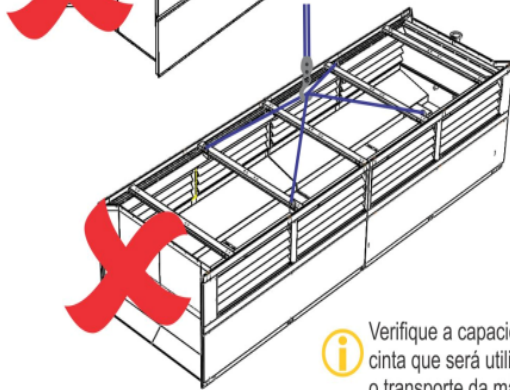

 Verifique a capacidade da cinta que será utilizada para o transporte da máquina.

2- Encaixar a parte superior na inferior;

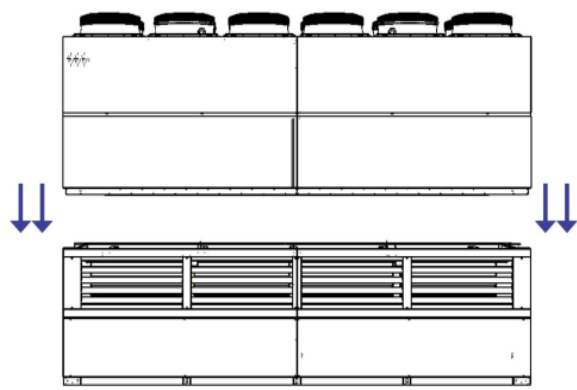

3- Abrir as portas para ter acesso interno;

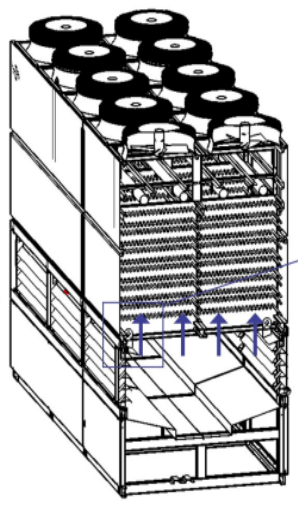

4- Observar folgas entre as peças. Alinhar folgas nos 4 lados.

